

EPAL 2 INDUSTRIAL PALLET

1,200 x 1,000 mm



The work of the European Pallet Association, its National Committees and licensees forms the stable basis for the successful, open pallet pool and enables the global exchange of EPAL load carriers. There are more than 650 million EPAL pallets in circulation around the globe that are used throughout the sector and it would be impossible to imagine industry and logistics without them. The design of the EPAL 2 industrial pallet makes it ideal for the heaviest of industrial loads. The perimeter base allows it to be transported on chains or roller conveyors. Constant quality assurance and high quality materials ensure trouble-free, safe performance for users and loading. Their multiple use saves a considerable amount of environmental and economic resources.

FACTS & FIGURES

Materials: 17 boards of quality timber, 9 wood-chip or solid wood blocks, 133 nails. Produced according to the EPAL Technical Regulations.

Length	1,200 mm
Width	1,000 mm
Height	162 mm
Weight	Approx. 35 kg
Safe working load	1,250 kg

When stacking laden pallets on a solid, even surface, the bottommost pallet must not exceed a load of max. 4,250 kg.

QUALITY CONTROL



EPAL's quality assurance ensures EPAL Euro pallets are of an internationally uniform and high quality. The inspection companies Bureau Veritas and CCIC complete more than 25,000 independent inspections every year on behalf of EPAL at the EPAL licensees' premises. This quality control of EPAL Euro pallets is the fundamental basis of reuse and exchange and therefore of the sustainability of EPAL Euro pallets.

MARKINGS

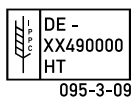

On the left- and righthand corner block:
"EPAL in oval"

On the middle block:
IPPC rectangle with IPPC ear of wheat, country code, pallet producer's IPPC number, HT (Heat Treatment); EPAL ID number with pallet producer's licence number and date of production (year, month);
EPAL control staple (on only one of the middle blocks):



HANDLING

4-sided accessibility with chamfered lower edge boards on both sides enables highly efficient handling during production, storage and transportation all the way along the supply chain. Compatible with all (conventional) standard load carriers, industrial trucks and warehouse systems.

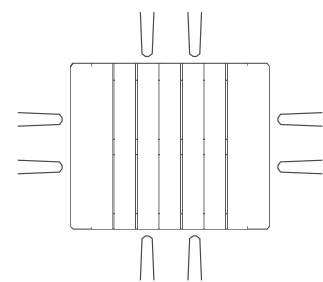

ISPM 15



During production, EPAL Euro pallets are heat treated (HT) in accordance with the IPPC ISPM 15 standard. This kills off any pests and protects trees, plants and other ecosystems from infestation. The ISPM 15 treatment ensures EPAL Euro pallets can be used to transport goods without limitation, internationally and across continents.

REPAIR



Damaged EPAL Euro pallets are cost-effectively repaired by more than 1,000 repair operations licensed by EPAL. Damaged QR codes can be reprinted or replaced while repairing EPAL Euro QR pallets. Repaired EPAL Euro pallets are marked on one of the middle blocks with an EPAL repair marking nail (with the EPAL logo and the repairer's licence number). The EPAL licence is evidence of the reliability of the repair operation and the high quality of the repair.



EPAL 2 INDUSTRIAL PALLET

1,200 x 1,000 mm



1,000 mm side

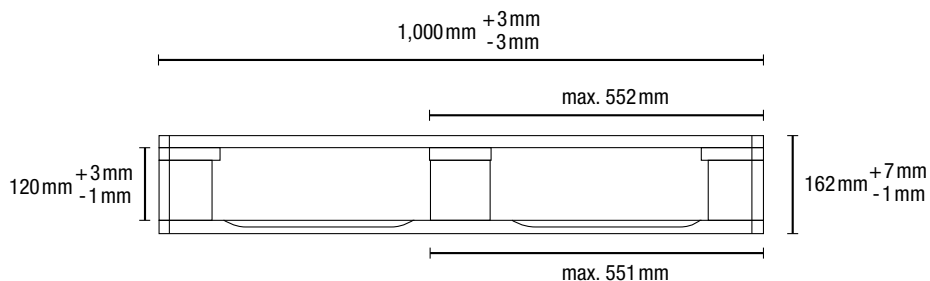

1,200 mm side

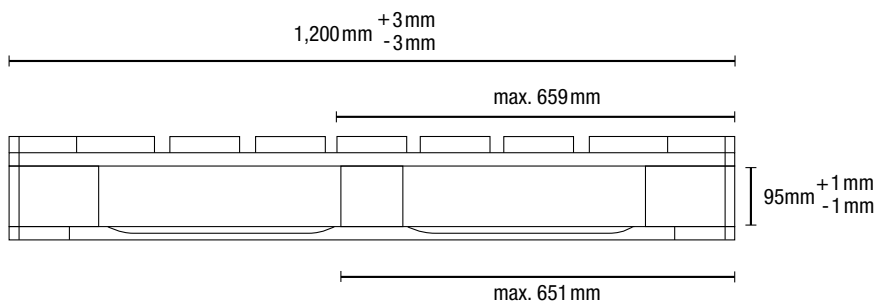

Top view

